

General information

Hybalans+ Wall plenum Supply/Extract adjustable 132x52 #2

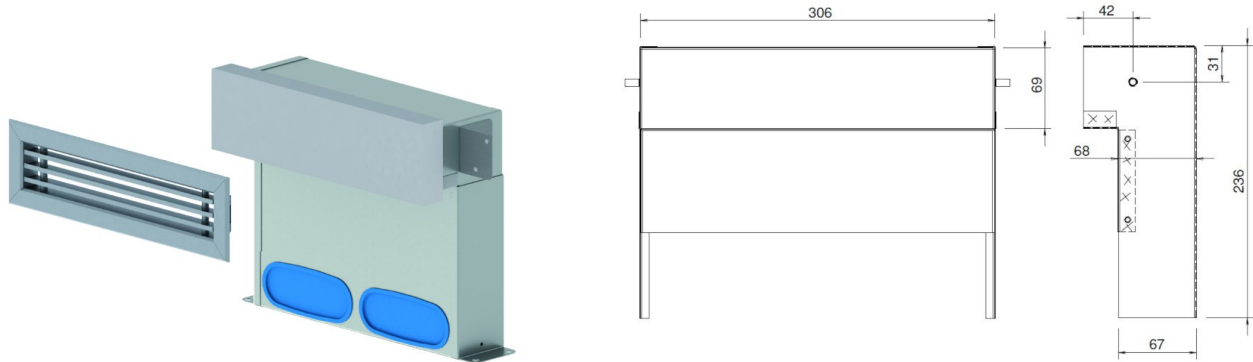

Specifications

Article number	400480446
Product category	Air extraction plenum / Air distribution
Material	Galvanized
Colour	Material own colour
Wall Thickness (mm)	1
Weight (kg)	2,5

Dimensions

Dimensions (l x w x h mm)	306 x 100 x 236
Connection diameter flexible (mm)	132x52
Connection diameter rigid (mm)	-

Application Insights

Intended use	Air
Supply / Extract	Supply/Extract
Number of connections	2
Temperature range (°C)	-25 / +80

Technical Specifications

Maximum air flow (m ³ /h)	100
Air Tightness Class	3
R-value (m ² K/W)	0
Other specifications	-

Floorplenum with 2x flexible duct 132x52mm

Pressure loss

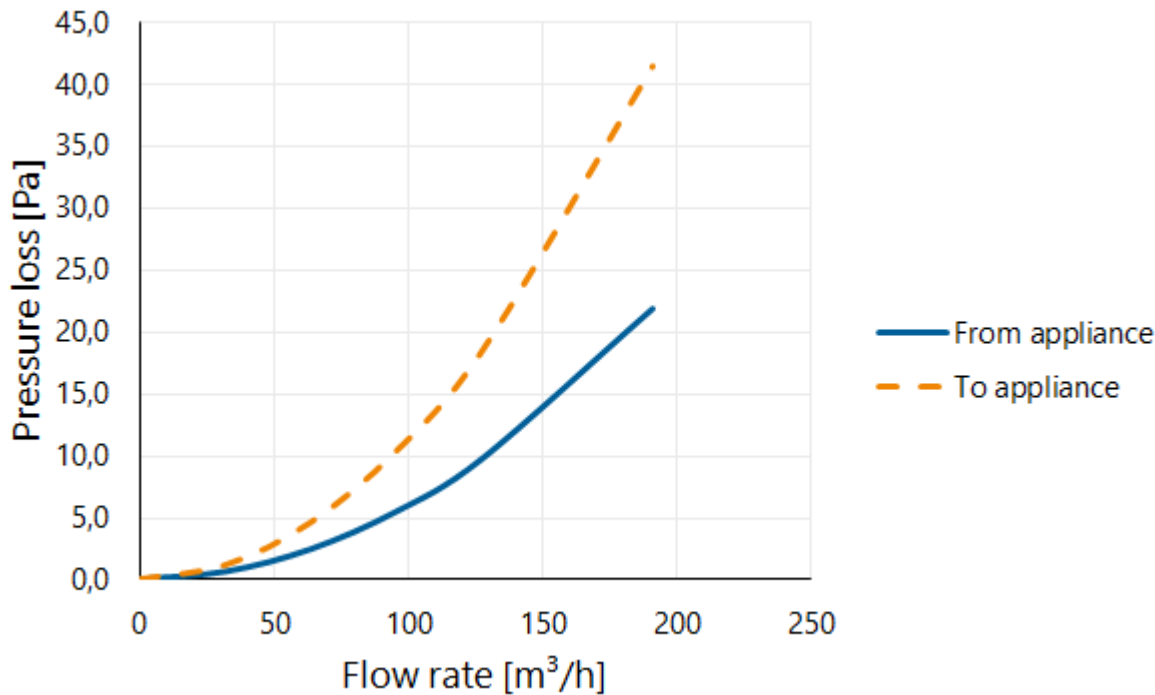

Wallplenum with flexible duct 132x52mm

Flow velocity pressure table

Flow rate			Static pressure loss	
[m/s]	[m³/h]	[l/s]	From appliance [Pa]	To appliance [Pa]
0	0	0	0,0	0,0
1	32	9	0,6	1,2
2	64	18	2,4	4,6
3	95	27	5,5	10,4
4	127	35	9,8	18,4
6	191	53	21,9	41,5